

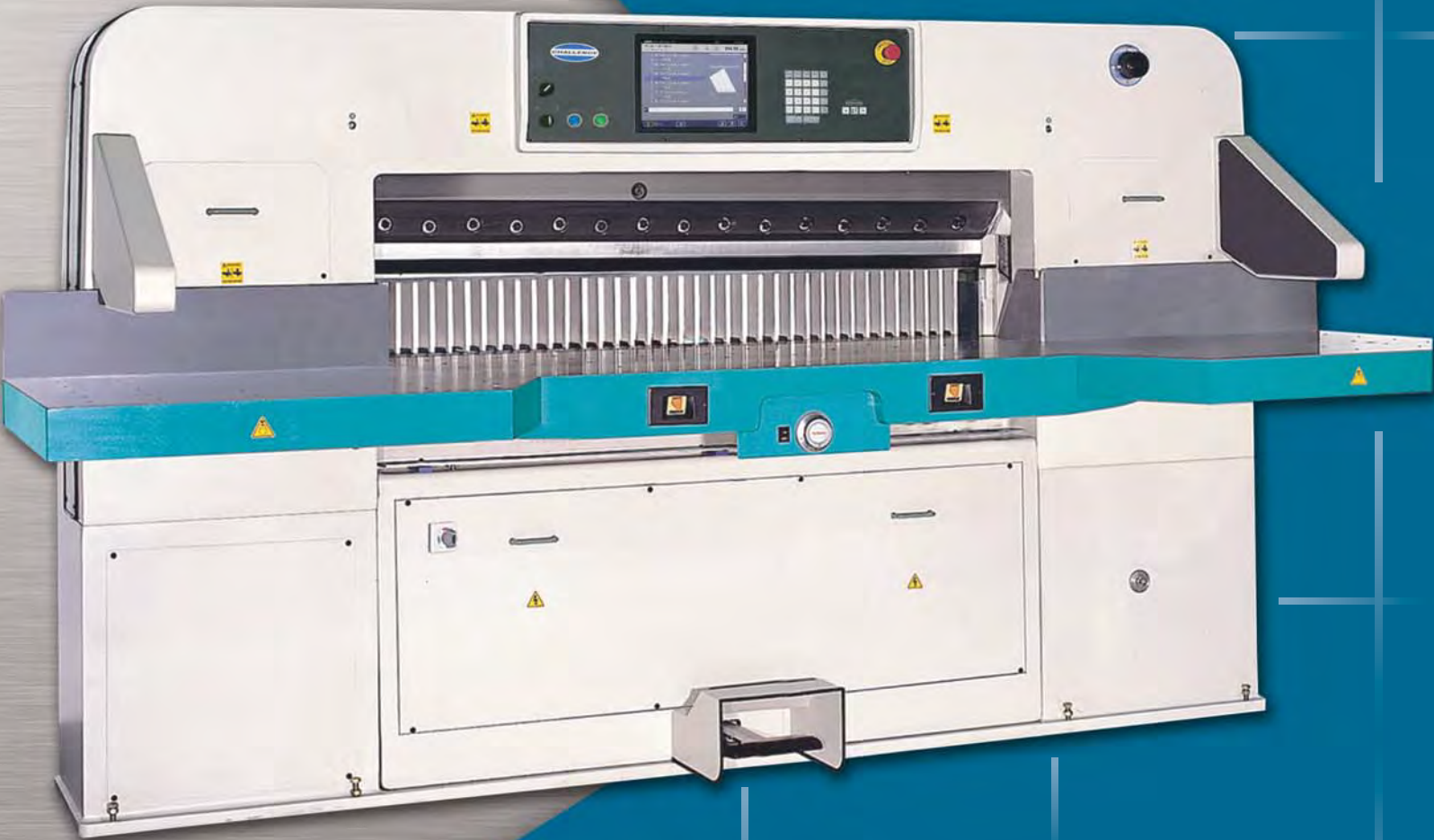

CHALLENGE HEAVY-DUTY

PAPER CUTTERS



iCUTTER 1550

ASSURANCE YOU MADE THE RIGHT DECISION

CHALLENGE HEAVY-DUTY PAPER CUTTERS

Mechanical drive paper cutters from Challenge Machinery provide precise, trouble-free operation at an incredible value!

GEAR-DRIVEN PAPER CUTTERS

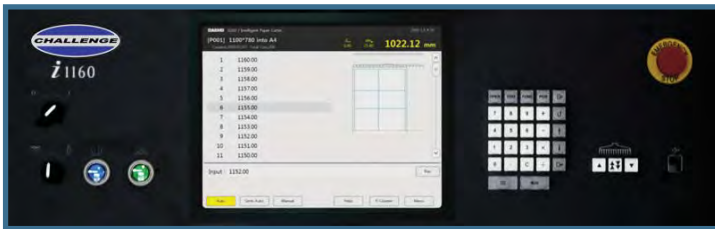

iCUTTER CONTROL PANEL

The available iCUTTER interface provides the platform for CIP/JDF integration. The larger 15" color touch-screen control panel gives the operator more job information at a glance. Machine maintenance reminders, complete self-diagnostics and error-detection, and advanced job storage/retrieval capabilities will bring your bindery into the next era of cutting proficiency.

PRECISE BACKGAUGE POSITIONING

Challenge Heavy-Duty paper cutters have a very rigid and stable backgauge due to the linear rail design that lifts the backgauge and guides it without undue stresses on the lead screw. The leadscrew utilizes a ball screw design, known for its reliability and accuracy at any speed.

SAFETY

A variety of standard safety features are found on Challenge Heavy-Duty paper cutters such as two-hand, timed and non-repeating cut buttons, monitored knife safety latch, infrared safety beams, and shear bolt detection. This allows our machines to carry the CE certification, assuring you of the highest level of operation security.

CUTTER FEATURES

- Manual/semi-automatic and automatic operation modes
- AC servomotor, ball screw and linear guide
- Adjustable clamping pressure
- Table light/optical cut line indicator
- Hard chromed air cushion table
- Easy knife change system
- Electro-magnetic clutch and brake system
- Double end pull knife drive system (single end pull on 860)
- Shear bolt detection
- Two hand cut buttons
- Infrared safety beams
- Closed door safety

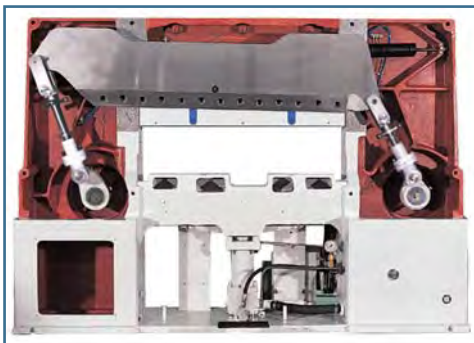

FOUNDATION OF STRENGTH

The rugged design of the Challenge mechanical-drive paper cutters starts with its cast-iron and steel construction. This heavy frame and knife bar design reduces twisting to provide consistent cutting accuracy.



KNIFE CHANGING SYSTEM

The Challenge Heavy-Duty cutter is designed for easy knife changes. This procedure allows for one operator to safely remove and install the blade in as little as ten minutes.



MPG (MICRO -ADJUSTING) HANDWHEEL

An electronically-controlled micro-adjust handwheel provides precision adjustments of the backgauge and can be turned OFF during machine operation.



iCUTTER 780

• Built for cutting system protection
 • Precise cut control with non-repeat safety system
 • Safety light curtain
 • Rear table



BACKGAUGE

The high-speed backgauge glides effortlessly and precisely across the table due to the linear guiderail and AC drive ball-screw.

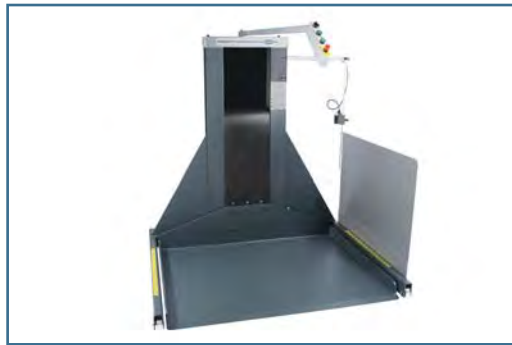

MATERIAL HANDLING

The PowerLift II provides powerful lifting/lowering capability for pallet sizes up to 55" x 41" providing increased productivity and reduced operator fatigue.

CHALLENGE HEAVY-DUTY PAPER CUTTERS

SPECIFICATIONS

		1550	1370	1160	780
CUTTING					
Maximum Cutting Width	A	61" 1550 mm	53.9" 1370 mm	45.7" 1160 mm	30.7" 780 mm
Maximum Clamp Opening	B	6.5" 165 mm	6.5" 165 mm	6.5" 165 mm	5.5" 140 mm
Feed Depth: Max.	C	61" 1550 mm	53.9" 1370 mm	45.7" 1160 mm	30.7" 780 mm
Min.		1.5" 38 mm	1" 26 mm	.94" 24 mm	.79" 20 mm
Cutting Speed (r.p.m.)		48	48	48	45
Drive System		Double End Pull	Double End Pull	Double End Pull	Single End Pull
Clamp Pressure		440-9921 lb 200-4500 kg	440-9921 lb 200-4500 kg	440-9921 lb 200-4500 kg	440-6613 lb 200-3000 kg
Backgauge Speed: Max.		13"/sec 33 cm/sec	13"/sec 33 cm/sec	13"/sec 33 cm/sec	13"/sec 33 cm/sec
Min.		.63"/sec 1.6 cm/sec	.63"/sec 1.6 cm/sec	.63"/sec 1.6 cm/sec	.63"/sec 1.6 cm/sec
Minimum Cut: w/ False Clamp		2.95" 7.5 cm	2.95" 7.5 cm	2.95" 7.5 cm	2.95" 7.5 cm
w/ Out False Clamp		1.5" 38 mm	1.0" 26 mm	.9" 24 mm	.79" 20 mm
DIMENSIONS					
Table Space: in front of knife	D	28.3" 720 mm	28.3" 720 mm	28.3" 720 mm	25.6" 650 mm
Table Height	E	35.4" 900 mm	35.4" 900 mm	35.4" 900 mm	35.4" 900 mm
Overall Length (w/side tables)	F	125.2" 3180 mm	112.8" 2865 mm	104.5" 2655 mm	75.6" 1920 mm
Overall Width	G	122.5" 3110 mm	105.5" 2680 mm	95.3" 2420 mm	64.6" 1640 mm
Overall Height	H	63.8" 1620 mm	65.2" 1655 mm	63.8" 1620 mm	59.1" 1500 mm
Net Weight (approximate)		12,125 lbs 5,500 kg	11,023 lbs 5,000 kg	9,149 lbs 4,150 kg	4,475 lbs 2,030 kg
Shipping Weight (approximate)		13,184 lbs 5,980 kg	11,533 lbs 5,231 kg	10,025 lbs 4,547 kg	5,145 lbs 2,334 kg
ELECTRICAL					
Motor		7.5 H.P., 208/230 Volts 60 Hz, 3 Phase AC, 40 Amps Service size 45 Amps	5 H.P., 208/230 Volts, 60 Hz, 3 Phase, AC, 25 Amps Service size 30 Amps.	5 H.P., 208/230 Volts, 60 Hz, 3 Phase, AC, 25 Amps Service size 30 Amps.	5 H.P., 208/230 Volts, 60 Hz, 3 Phase, AC, 25 Amps Service size 30 Amps.

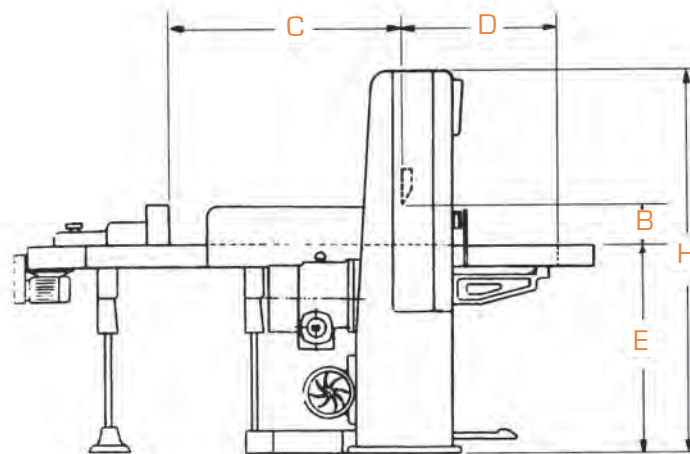
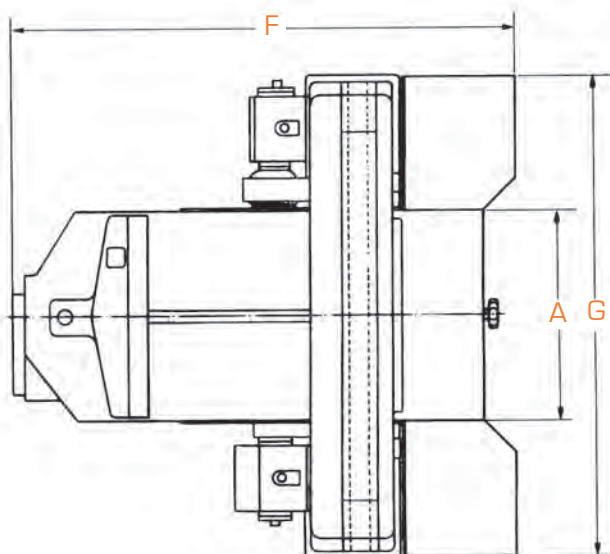

Challenge reserves the right to make changes to any product or specification without notice and without incurring responsibility to existing units.
 *Challenge is a registered trademark of The Challenge Machinery Company. All rights reserved.

ADV-012/500/GPCO/0924



960 Brook Road, Unit 3
 Conshohocken, PA 19428
 (215) 425-0300

THE CHALLENGE MACHINERY COMPANY
 6125 Norton Center Dr. Norton Shores, MI 49441 USA
 Phone: 231.799.8484 Fax: 231.798.1275 www.challengemachinery.com