

TRIMMING

# iCE TRIMMER HT-300

**NEXT GENERATION BOOK TRIMMER  
WITH HIGHER PRODUCTIVITY AND  
MORE AUTOMATION**



## BENEFITS

### HIGH SPEED

New features such as auto book thickness measurement increase the maximum production speed up to 300 books/stacks per hour (4 books/stack x 3 = 1,200 bph).

### LABOR SAVINGS

The HT-300 can be connected with Horizon perfect binders and output conveyers for in-line book production efficiency.

### UNIQUE TRIMMING FEATURE

Differentiating corner cut capability. The rotary table in the trim section enables not only three-side trimming but also finishing in a variety of shapes.

### CONFIGURATION FLEXIBILITY

Multiple options\* for the feeder and delivery unit allow for flexible machine configurations depending on your needs.

\* For the feeder: stack or pusher in feed  
For the delivery unit: delivery stacker or conveyor (front/side)

# SPECIFICATIONS.



(Top View)

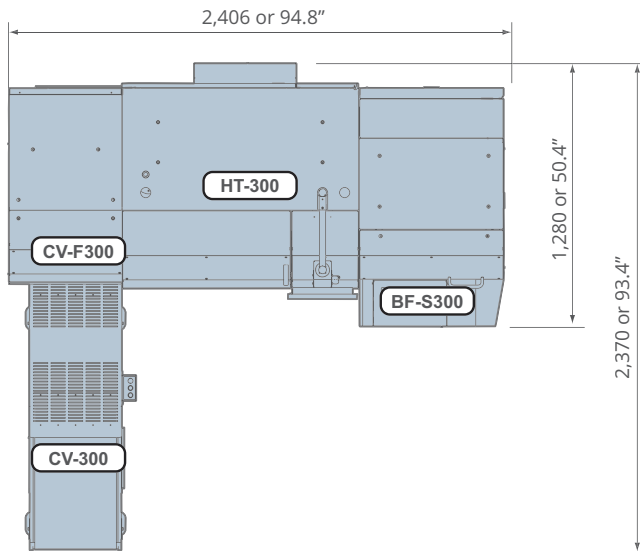

(Side View)

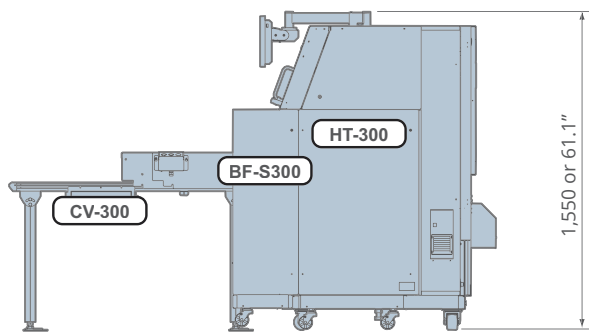

## MANAGE YOUR BINDERY WITH HORIZON'S BINDERY CONTROL SYSTEM

The ICE Series can be enhanced with JDF workflow from upstream to postpress using the Horizon pXnet Bindery Control System / ICE LINK. ICE LINK is the next generation of pXnet.

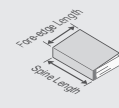
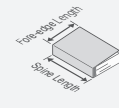

HT-300	
Untrimmed Book Size Spine	 <p><b>Length x Fore-edge Length</b></p> <p><b>Standard Tables</b>            Table A for portrait:            Max. 350 × 235 mm or 13.775" × 9.250"            Min. 277 × 206 mm or 10.910" × 8.115"            Table B for portrait:            Max. 350 × 235 mm or 13.775" × 9.250"            Min. 204 × 136 mm or 8.035" × 5.355"            Table C for landscape:            Max. 320 × 350 mm or 12.595" × 13.775"            Min. 211 × 275 mm or 8.310" × 10.830"            Table K for A6:            Max. 320 × 219 mm or 12.595" × 8.620"            Min. 152 × 107 mm or 5.985" × 4.215"</p>
Finished Book Size	 <p><b>Length x Fore-edge Length</b></p> <p><b>Standard Tables</b>            Table A for portrait:            Max. 340 × 230 mm or 13.385" × 9.055"            Min. 273 × 204 mm or 10.750" × 8.035"            Table B for portrait:            Max. 340 × 230 mm or 13.385" × 9.055"            Min. 200 × 134 mm or 7.875" × 5.280"            Table C for landscape:            Max. 340 × 305 mm or 13.385" × 12.005"            Min. 207 × 273 mm or 8.150" × 10.750"            Table K for A6:            Max. 305 × 217 mm or 12.005" × 8.540"            Min. 148 × 105 mm or 5.830" × 4.135"</p>
Trim Width	Max. 99.9 mm or 3.930" Min. 2 mm or 0.080" "0" can be entered (no trimming).
Trim Height	Max. 51 mm or 2.005" Min. 1 mm or 0.040"
Clamp System and Pressure	Servo motor 1 through 7 kN (100 through 700 kgf)
Book Stack Height	BF-S300 Suction Feeder 300 mm or 11.81"
Production Speed	<b>BF-S300 Sucker Feeder</b> When trimming one book: Max. 160 through 300 books per hour When trimming multiple books: 280 through 590 books per hour  <b>BF-P300 Pusher Feeder</b> When trimming one book: Max. 160 through 300 books per hour When trimming multiple books: (160 through 300 × number of stacked books) per hour
Voltage/Frequency	200-240 V, 50 or 60 Hz (400 V, step down to 200 V by transformer)
Machine Dimensions	<b>When the BF-S300 sucker feeder is connected:</b> 2,406 (W) × 1,280 (D) × 1,550 (H) mm or 94.7" (W) × 50.4" (D) × 61.0" (H)  <b>When the BF-P300 pusher feeder is connected:</b> 2,406 (W) × 3,187 (D) × 1,550 (H) mm or 94.7" (W) × 125.5" (D) × 61.0" (H) Note that the dimensions of the CV-300 + CV-S300 side conveyor, CV-300 + CV-F300 front conveyor are not included

**Horizon**

Horizon International, Inc.

510 Kuze Ooyabu-cho, Minami-ku,  
Kyoto, 601-8206, Japan  
Phone : +81-75-934-6700  
Fax : +81-75-934-6708  
www.horizon.co.jp

Distributed by

 **STANDARD**

Standard Finishing Systems

10 Connector Road, Andover,  
MA 01810  
Phone : 877-404-4460 / 978-470-1920  
Fax : 978-470-2771  
www.standardfinishing.com

*Established 1902*  
**Northern**  
MACHINE WORKS

2817 Cedar St. Philadelphia, PA 19134  
(215) 425-0300  
www.northernmachine.com