

# Horizon



215-425-0300  
northernmachine.com

CUTTING

# APC-610

User-friendly,  
Programmable Cutter.



# ADVANCED PROGRAM FOR EASY SET-UP.

Compact hydraulic cutting system with accurate cutting quality and simple operation.



## OPERATOR SAFETY

### STANDARD EQUIPPED AREA SENSORS

If the area sensors detect any objects, the cutting motion will stop immediately. These sensors meet the high level of safety specified in Category 4 according to ISO13849-1.

### DOUBLE SAFETY CIRCUIT

The system is further equipped with a hard-wired secondary safety interrupt for operator safety.

## 1 CONTROL PANEL

The large color touchscreen provides intuitive operation. The Simple Program Setting screen displays sheet rotating direction and cutting order graphically.



## 3 BACKGAUGE

The servo-motor driven backgauge assures accurate positioning and repeatability for consistent quality production.



## 2 KNIFE

Maximum cutting width is 610 mm or 24.0", maximum cutting height is 100 mm or 3.39".

The cutting knife is made of special steel ensuring consistently high standard cutting quality for a prolonged period of time.

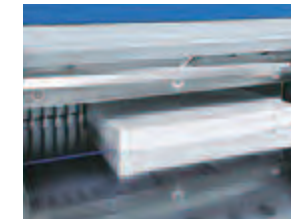

## 4 KNIFE ANGLE ADJUSTING LEVER

Knife angle and cutting depth adjustments are easily done on the front side of the cutter.



# SPECIFICATIONS.

Machine Dimensions (Unit: mm or inch)

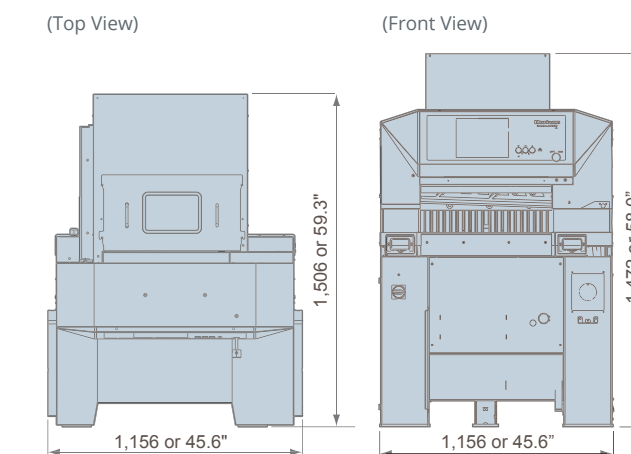

## APC-610 SPECIFICATIONS

Cutting Width	Max. 610 mm or 24.0"
Cutting Height	Max. 100 mm or 3.93" (95 mm or 3.74" using the support plate)
Cutting Depth	Max. 620 mm or 24.4" Min. 25 mm or 0.98" (65 mm or 2.56" using the support plate)
Clamp System and Pressure	Hydraulic Powered 5 to 20 kN or 500 to 2,000 kgf
Job Memory	99 Steps, 200 Jobs
Push-out Length	20 to 150 mm or 0.785" to 5.905" Adjustable
Cutting Speed	3.8 seconds per cycle
Voltage/Frequency	3-Phase 200 to 220 V, 50 or 60 Hz 3-Phase 380 / 400 / 415 V, 50 or 60 Hz Single phase 200 to 220 V, 50 or 60 Hz
Machine Dimensions	W1,156 x D1,506 x H1,472 mm or W45.6" x D59.3" x H58.0"

## BENEFIT

### HIGHT QUALITY

Hydraulic clamping and cutting mechanism ensures accurate cutting quality. Servo motor driven backgauge for accurate positioning.

### USER-FRIENDLY OPERATION

The color touchscreen is intuitive and icon-based for user-friendly operation. The Operation, Setting and Information Screens are used for efficient and accurate operation.

### SAFETY OPERATION

The APC-610 is activated only when the two cut buttons are simultaneously pressed. Also, if the standard equipped area sensors detect any object, the cutting motion will stop immediately.

### MANAGE YOUR BINDERY WITH PXNET

The system can be further enhanced with Horizon's pXnet bindery control system which integrates JDF workflow from upstream devices.

**MORE AT**  
**HORIZON.CO.JP**



**Horizon**

Horizon International, Inc.

510 Kuze Ooyabu-cho, Minami-ku,  
Kyoto, 601-8206, Japan  
Phone : +81-75-934-6700  
Fax : +81-75-934-6708  
[www.horizon.co.jp](http://www.horizon.co.jp)

Distributed by

 **STANDARD**

Standard Finishing Systems

10 Connector Road, Andover,  
MA 01810  
Phone : 877-404-4460 / 978-470-1920  
Fax : 978-470-2771  
[www.standardfinishing.com](http://www.standardfinishing.com)