

# CRA-36

Auto Creaser

Creasing, perforating and slitting can be performed in one pass.



## Features

- 1. Sharp Creasing** - Suitable for creasing covers, restaurant menus, shop cards, greeting cards and laminated sheets. The impact creaser avoids cracking on digitally-printed applications.
- 2. Preparing Perfect Bound Book Covers** - Impact creasing helps to prepare high quality perfect bound book covers. Spine, hinge and flap creases can be properly produced by selecting up or down creasing.
- 3. Perforation** - The supplied impact perforation unit and the optional rotary perforation unit enables perforation in both directions. Coupons or tickets can be perforated in one pass.
- 4. JDF Workflow** - The system can be further enhanced with Horizon's pXnet bindery control system which integrates JDF workflow from upstream devices.

Multiple functions  
System enables c  
gutter/edge



The trims from the optional rotary cutter unit are ejected to the tray. This tray is not necessary when the rotary cutter unit is not being used.

## Creasing

Select the up creasing or down creasing. Up to 10 creasing lines can be produced.

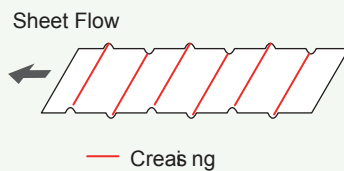

## Creasing along the fold line

The creasing line can be made along the fold line.

\* Creasing only and folding can not be performed.

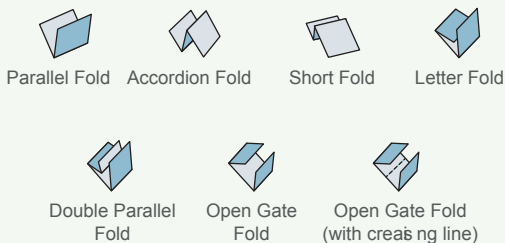

## Available creasing and perforation patterns.

### Covers for Perfect Binding (Creasing Patterns)

A wide variety of covers for perfect binding can be produced.

\* Creasing only and folding can not be performed.

Creasing and perforation set up can be done with the intuitive touch screen.

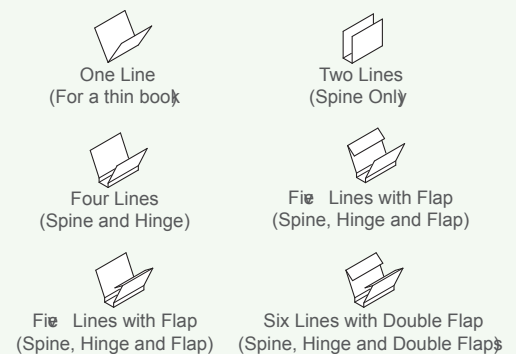

are built into a compact system.  
creasing, perforation, slitting and  
trimming all in one pass.

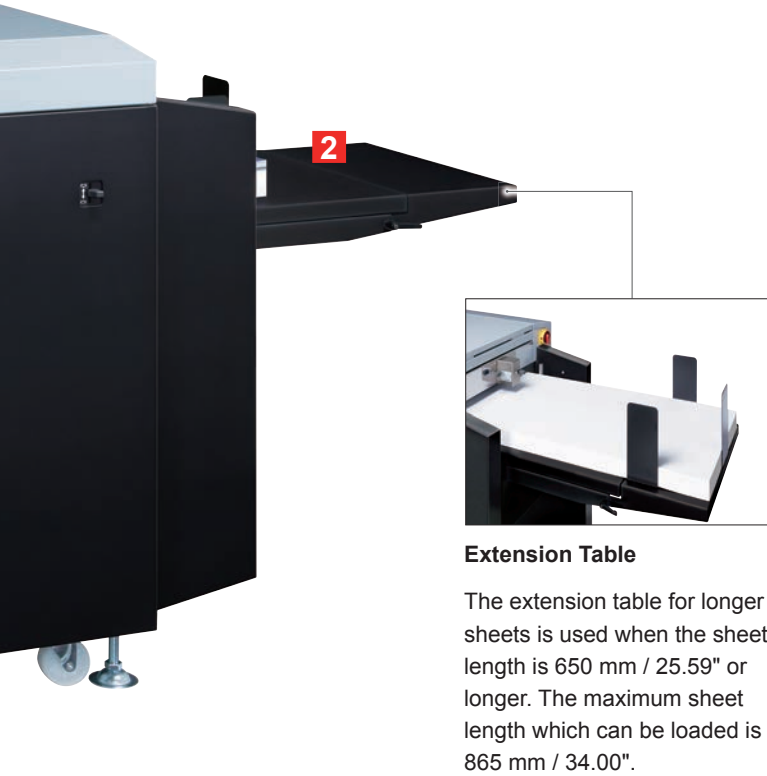

**Extension Table**

The extension table for longer sheets is used when the sheet length is 650 mm / 25.59" or longer. The maximum sheet length which can be loaded is 865 mm / 34.00".

## Impact Perforation

Perforation is available by installing the supplied impact perforation unit.

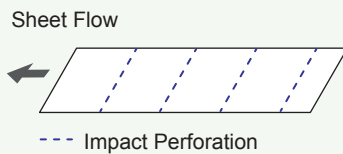

Perforation can be installed in the creasing section. A wide variety of creasing blades are available for different perforating patterns.

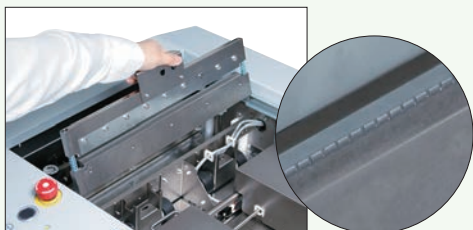

## 1 Touch Panel

Changeovers including creasing number and up / down crease selection can be done easily at the new high resolution touchscreen. Up to 200 jobs can be stored in memory for easy recall.



## 2 Reliable Sheet Feeding

Uniquely designed suction belt feeding system enables stable feeding performance even with heavier sheets. An ultrasonic sensor ensures miss or double detection regardless of the print image or thickness of sheets.



## 3 Sheet Registration

Sheets align to the register guide to ensure straight feeding for accurate creasing. Sheet skew can be adjusted by changing the transport roller pressure on the registration guide.

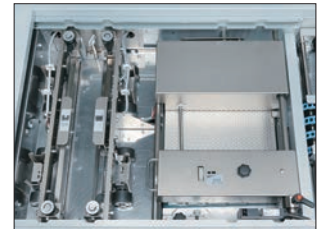

## 4 Quality Creasing

The standard equipped creasing unit performs normal creasing, creasing for folding and creasing for covers. Perforation is also available by installing the supplied impact perforation unit.



## 5 Delivery Section

Creased jobs are delivered on the tray.

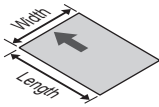

## CRA-36 Specifications

Installation Type	Floor Model	
Sheet Feeding System	Air Suction Feed Belt	
Sheet Size		<b>Width x Length</b> Max. 364 x 865 mm or 14.33" x 34.05" Min. 105 x 180 mm or 4.14" x 7.09"
	For mm version A3, JIS B4, A4, JIS B5	
	For inch version 12"x18", 11"x17", 8.5"x14", 8.5"x11"	
Sheet Weight Range	Normal Paper	80 to 400 gsm
	Coated Paper (Gloss, Matte)	105 to 400 gsm
	Laminated Paper	0.2 to 0.5 mm or 0.0079" to 0.0196"
	The sheet range is limited when the impact perforation unit is used. Normal Paper: 80 to 210 gsm Coated Paper (Gloss, Matte): 105 to 256 gsm	
Feeder Stack Height	Max. 150 mm or 5.90"	
Impact Creasing Mechanism	One set of positive and negative	
Number of Impact Crease Lines	Max. 10 Creasing Lines	
Production Speed	5,000 sheets per hour (A4, short-edge feeding, one creasing line)	
Voltage/Frequency	Single Phase 100 to 120 V, 50 or 60 Hz Single Phase 200 to 240 V, 50 or 60 Hz	
Rated Current	Single Phase 100 to 120 V, 50 or 60 Hz, 7.2 A Single Phase 200 to 240 V, 50 or 60 Hz, 3.0 A Single Phase 115 V, 50 or 60 Hz, 5.7 A	
Machine Dimensions	W2,427 x D701 x H1,043 mm or W95.6" x D27.6" x H41.1"	
Machine Weight	Main Body: 228 kg or 502.2 lb Accessories: 20 kg or 44.1 lb	

## Machine Dimensions (Unit: mm or inch)

Provide 700 mm / 27.6" of space around the machine.

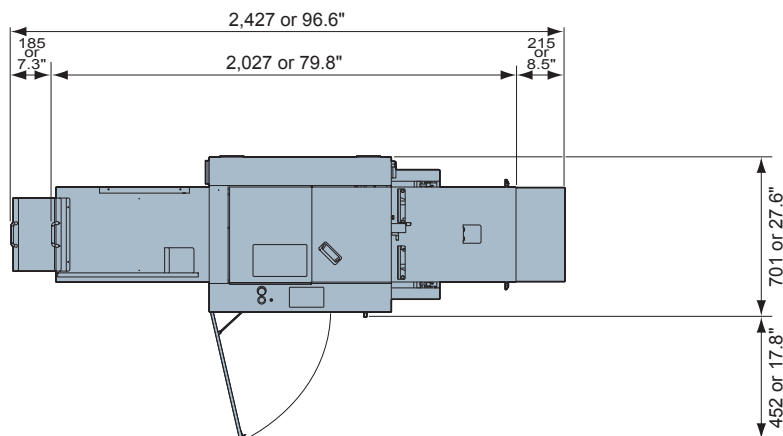











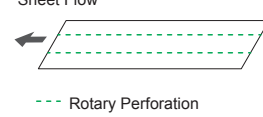



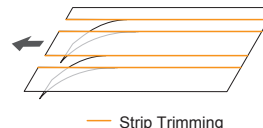

\*The machine design and specifications are subject to change without any notice.

# Horizon

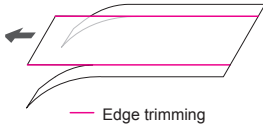
## HORIZON INTERNATIONAL, INC.

510 Kuze Ooyabu-cho, Minami-ku, Kyoto, 601-8206, Japan  
Phone : +81-(0)75-934-6700 Fax : +81-(0)75-934-6708  
www.horizon.co.jp

## Options

Rotary Cutter Unit	<p>The rotary cutter unit performs the perforation which is parallel to the sheet flow, strip trimming and slitting. The rotary cutter unit can be used with the creasing and impact perforation at the same time.</p> 		
	<p>CRA-CP : Perforation Kit</p>  <p>Sheet Flow --- Rotary Perforation</p>	 Perforation Wheel 2 pcs  Lower Blade 2 pcs  Upper Drive Roller 2 pcs  Perforation Guide 3 pcs  O-ring (spare) 4 pcs	
	<p>CRA-ST : Strip trim kit</p>  <p>Strip Trimming</p>	 Strip Trim Wheel 2 pcs  Lower Blade 4 pcs  Upper and Lower Trim Guides 1 each  O-ring (spare) 4 pcs	
	<p>CRA-ET : Edge Trim kit</p>  <p>Edge trimming</p>	 Edge Trim Wheel 2 pcs  Lower Edge Trim Blade 2 pcs  Drive Roller 2 pcs  Trim Guide (F/R) 1 each  O-ring (spare) 4 pcs	
Impact Creasing Unit	<p>One unit is included as a standard option. Creasing units for different width creasing lines are available. (Standard width is 0.8 mm / 0.031") - 1.3 mm / 0.512" (thick) - 2.0 mm / 0.079" (thick)</p> 		

Established 1902  
**Northern**  
machine works

**northernmachine.com**  
**215-425-0300**